

FOURWHEEL DRIVE DUMPER

CAPACITY:

Max. safe load:	1500 kg
Heaped:	825L
Struck:	658L
Water:	494L

ENGINE:

Deutz D2009L03 3 Cylinder, Water Cooled, Naturally Aspirated	
Displacement:	1.7 L
Max. power:	24.7kW/33bhp @ 2500 rpm
Max. torque:	104Nm @ 1600 rpm
Emissions:	Euro 2 compliant

TRANSMISSION:

Hydrostatic automotive "Twin Lock" permanent 4 wheel drive
Acceleration by foot pedal & braking from hydrostatic retardation

DRIVE CHARACTERISTICS:

Forward / Reverse	0-12 km/h (0-7.5 mph)
Steering angle:	+/- 36.5°
Turning Circle:	6.55m
Grade-ability:	50%
Tyres:	10.0 / 75 / 15.3 (traction Profile)
Steering:	Priority load sensing hydrostatic centre pivot
Working brakes:	Hydrostatic retardation
Park brake:	Automatic in rear wheel motors

NOISE LEVELS:

LWA	101dB(A)
LPA	85dB(A)

TANK CAPACITIES:

Fuel:	29L
Hydraulic:	29L

SKIP:

Hydraulically operated skip tipping to 91°
Heavy duty fully welded skip with 5mm thick steel, reinforced upper side walls for greater strength
Operated by a multi axis joystick for increased performance

ELECTRICAL:

Heavy duty 335 Battery: 12V, 95Ah
Wiring harness in protective sleeving
Reversing alarm

HYDRAULICS:

35cc Automotive control hydrostatic pump @ 300 bar
14cc Gear pump @ 170 bar
Hydraulic test points fitted as standard
Easy access return oil filter on top of tank

SEATING & CONTROLS:

Adjustable suspension seat accessible from both sides
Clear access across dumper via galvanised steps
Super bright warning lights on fully featured display instrument
Steel constructed centre console for extra leg protection
Column mounted directional control lever
Anti-slip floor

SERVICE ACCESS:

Easy access for service maintenance
Lockable hinged engine cover
Battery mounted inside the engine bay

We reserve the right to change the above specifications without prior notice

HT1.5

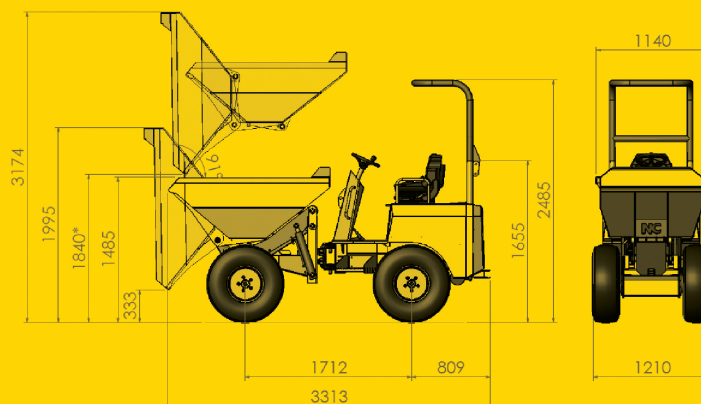

FEATURES

- Unrivalled operator accessibility and comfort
- Excellent rough terrain performance from permanent 4-wheel drive
- Heavy duty construction; skip manufactured from 8mm steel plate and reinforced around top
- Column operated forward and reverse directions with acceleration by foot pedal
- Simple and safe operation; drive direction on the steering column
- Heavy duty centre console for leg protection
- Simple instrument panel including fuel gauge, hourmeter, warning lights for parking brake, oil temperature, oil pressure, engine temperature
- Folding ROPS as standard
- Easy access to engine compartment for service and maintenance
- Recovery bracket as standard
- 33.1 HP engine /24.7 Kw
- Excellent power to weight ratio
- Theft deterrent Cesar Data Tag System as standard
- Ample ground clearance
- Excellent turning circle
- Reversing alarm standard
- Separate fuel and hydraulic filler compartments
- Skip tips over 90°
- Adjustable suspension seat

OPTIONAL EQUIPMENT

- Road Light Kit
- Flashing Beacon
- Spare Wheel
- Biodegradable Hydraulic Oil
- FOPS Roof
- Skip manufactured from ST52 or Hardox
- Cab



NC Engineering (Hamiltonsbawn) Ltd
2 Killyrudden Road, Hamiltonsbawn
Richhill, Co Armagh
Northern Ireland BT61 9SF

Tel: +44 (0) 28 3887 1970
Fax: +44 (0) 28 3887 0362

Email: sales@nc-engineering.com
Web: www.nc-engineering.com